

# A Novel Approach to Higher Education in Electrical, Electronics and Information Engineering

Michael H.W. Hoffmann

*Department of Microwave Techniques, University of Ulm, Germany*

[michael.hoffmann@ieee.org](mailto:michael.hoffmann@ieee.org)

## Abstract

*In this paper, a novel idea is introduced concerning reorganization of curricula in electrical, electronics and information engineering. It aims at shortening the average duration of education while preserving its quality. It is based on a suggestion that was discussed recently, namely to modularize educational materials. However, rather than regrouping curricula only roughly into smaller lectures that can be combined according to requirements, it is suggested that even basic subjects should be modularized and interlocked with modules from other subjects. This will relieve lecturers of introducing material that was already taught by other colleagues, thus clearing time for further subjects. As a side effect, students feel better motivated, since they recognize interactions between subjects as early as possible.*

## 1. Introduction

A natural consequence of the rapid growth of knowledge in electrical, electronics and information engineering would be the extension of the duration of studies. However, institutions for higher education are even urged to shorten the average duration of education because of rising costs and industrial needs.

As a reaction to these claims, many subjects are cancelled that used to be part of a well-grounded engineering education. Courses are shortened, in order to make time schedules more effective. As a side effect, comprehension of subjects is worsening. Some institutions are even lowering the requirements for the first degree.

In summary, the quality of higher education is at risk to fall off – in not only electrical, electronics and information engineering. Too rarely, it is thought of a thorough reorganization of higher education.

One of the reasons for this unpleasant development is that many of those responsible for educational policy are used to think in terms of election periods rather than in the long-term planning. Therefore, a majority of them prefers administrative solutions that have advertising appeal

instead of solutions, which require potentially unpopular measures.

An example is the “Joint declaration of the European Ministers of Education”, convened in Bologna on June 19, 1999 [1] that provides nice looking agreements between ministries of European countries. A closer look at conversions of that declaration into national laws and regulations, however, reveals that these agreements might effectively worsen the quality standard of national educational models. In Germany, for instance, a three-years bachelor degree of expectedly inferior quality (compared to the German Diplom-degree) will be fostered in the future. It could be suspected that an essential but hidden aim of these agreements is the commercialization of higher education in Europe, which saves governments a considerable amount of money - to the debit of students’ account. (See also [2]).

It is thus high time that professional educators take the initiative to put their ideas into concrete terms, at least to hold the quality standard of higher education. Therefore, this paper aims at initializing a novel approach in higher education of electrical, electronics and information engineering by reorganization of curricula. It saves students as much time as possible without loss in comprehension of the taught material.

## 2. Conventional curricula

Conventional curricula are grown structures, at least those that are in use for five or more years. (Newer curricula are already influenced by political pressure). These curricula are characterized by a subdivision into two parts, a first part that imparts fundamentals, and a second part that instructs on special subjects. This structure is particularly developed at German universities where even two years are needed for the first part.

Subjects of the first part are taught nearly independently from each other in the first year (see Fig. 1). The advantage of this scheme is the autonomy of the individual subject: lecturers are independent from contents of other subjects. There is thus no need to accept compromises.

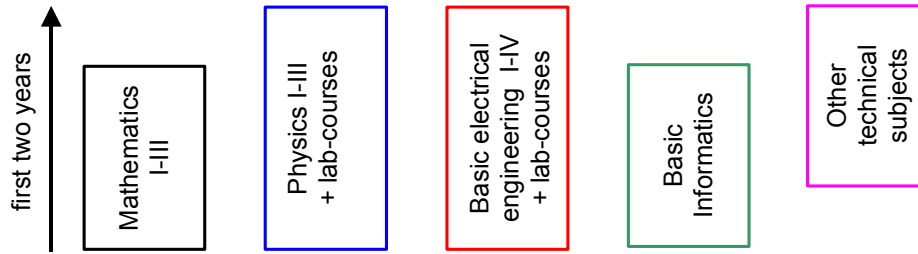

**Figure 1:** Conventional curriculum for the first four semesters in electrical and electronics engineering in Germany; subjects will be taught nearly independently from one another

However, what is a strength in this scheme is at the same time a weak spot.

First, students do not see in good time what the subject is good for and how it is linked to other subjects. Thus, they often feel uncomfortable.

Furthermore, since lecturers of other subjects cannot be sure whether a certain technique of a related subject has already been introduced, they often feel constrained to introduce this technique (again) by themselves, which is time consuming. This is one of several reasons why studying following conventional curricula requires relatively long time.

In some European countries, a reduction of basic subjects was therefore introduced, which gives students the opportunity to see the links between subjects earlier, and which reduces dependencies.

However, to preserve the quality standard of the courses, the “saved” time for basic subjects must be rescheduled at a later point in time. Since then the context of parts of these subjects is lost, it is sometimes even necessary to spend more time as was saved earlier.

Consequently, some universities have lowered their requirements for awarding a degree, either by reducing the number of credits to be earned or by reducing the quality standard.

It is reported by colleagues that in top universities of

the United States of America, therefore, a restructuring of curricula for good students is discussed. These students are supposed to be guided directly to a master’s degree without being awarded a bachelor’s degree. In the new curricula, subjects are more strongly meshed than in conventional curricula.

The trend in the US seems thus to be opposite to the intentions of the European ministers of education.

### 3. K.C. Gupta’s concept modules

Since the weak points of conventional curricula have been recognized by many lecturers, a stronger modularization of curricula has been discussed. K.C. Gupta [3] from the University of Colorado at Boulder suggests a very promising step into this direction. He proposes “...restructuring the courses into primary concept modules and interlinking these modules to reflect the logical development of knowledge in the domain of the discipline being studied”.

As a tool for segmentation of a course and its development, he uses concept maps [4]. Fig. 2 shows how he opposes the conventional structure of a lecture on microwave engineering to a structure using concept modules.

While in the conventional structure only a subdivision

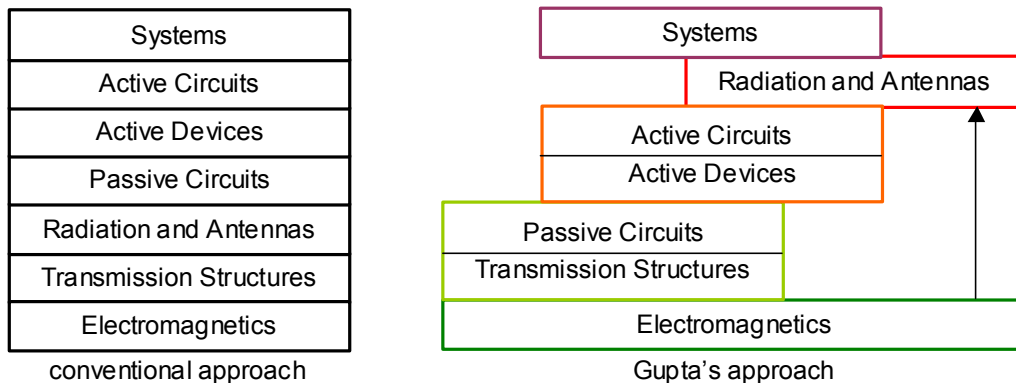

**Figure 2:** Conventional structure vs. Gupta’s structure [3]

into chapters is given that all students must learn, in Gupta's structure a segmentation into modules is seen that consist of one or more chapters. Each student attends only those modules that are necessary for his or her further studies.

#### 4. Micro-modularized curricula

While Gupta aims at segmenting one given particular subject into modules, this paper proposes a more far-reaching subdivision into micro-modules or learning-modules that even cross borders between individual subjects. The following fictitious scenario illustrates this.

Suppose that a professor of the physics department is about to give a lecture on a basic course on electrostatics for engineers. The day before, he has demonstrated some experiments on electric charges. Now, he is going to perform experiments on the force that is imposed on a test charge by other charges. At that time, he cannot yet assume that students are already familiar with vector-algebra let alone with vector-analysis.

Therefore, vectorial quantities and the basics of vector-algebra must be taught to students. Wouldn't it be a good idea, if his colleague from the mathematics department supported him? Therefore, a colleague who normally teaches engineering mathematics accompanies him.

She will take over to introduce elementary parts of vector-algebra rigorously after he has given the motivation for it. That is, they segment the lecture into learning-modules, some modules that consist mainly of physics content, some others that consist mainly of pure mathematics.

Since it is necessary that the mathematics lecturer give a careful explanation, she will need some hours of time. Therefore, the physics professor will leave his colleague and the students for the next hours.

In the following days, both lecturers will have to instruct students separately, since each of them will have

to give students further instructions. Soon there will be a new situation, where they depend on each other. They will have to continue their cooperative teaching repeatedly.

In that way, the complete lecture could be segmented into learning-modules. Obviously, Gupta's concept-modules could be good starting entities for micro-modularization.

The advantage of a method as described above is that each expert lecturer teaches on material where he or she has his or her expertise. Furthermore, each of them knows about what was taught in the other fields.

This will relieve lecturers of introducing material that was already taught by other colleagues, thus clearing time for further subjects.

The drawback is that lecturers are no longer independent.

#### 5. Problems to be faced

A reorganization of curricula that makes rigorous use of learning-modules creates some problems.

First, a scenario as the above one requires a thorough analysis of the material that is to be taught. Learning-modules must be arranged that their interfaces fit together.

Next, there is kind of a social problem within a faculty or even between members of different faculties. This is "assets protection". It is frequently seen that some lecturers watch jealously "their" subjects. At least in Germany, professors use the argument of the "freedom of teaching in higher education". That is, each professor is permitted to design the lessons of a subject according to his or her personal ideas.

The most severe problem, though, is concerning the financial aspect. A rough estimation of the amount of work, of time and of staff involved, is rather sobering. Thus, with conventional means, that idea would not be realizable.

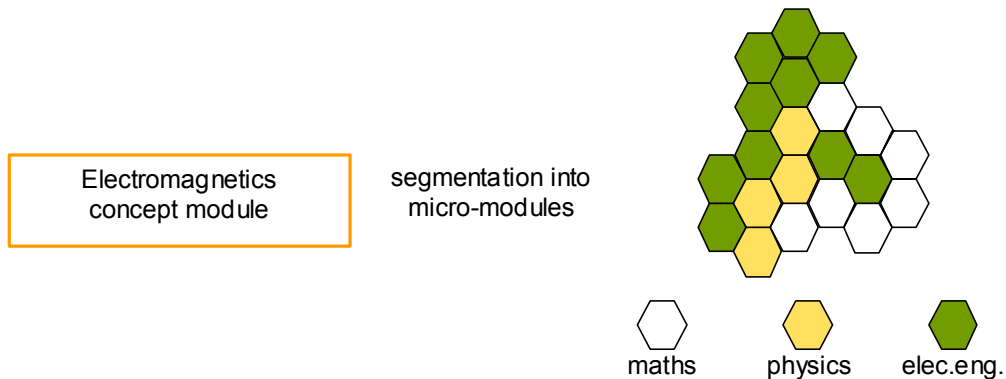

Figure 3: Micro-modularized structure

## 6. Vision of a solution

Is micro-modularization thus only an educational fantasy? An analysis of the above described problems raises hopes.

The first problem (reorganization of curricula, analysis of the material) is the simplest one, since it can be solved on a purely logical basis. A very useful tool for an analysis of subjects and their interdependencies is the idea of using concept maps following Buzan and Buzan [4]. Gupta [3] has already successfully applied this idea to an analysis of a lecture on microwave engineering. Thus, the functional aspects of project management can be solved.

The second problem (assets protection) is a social problem that ought to be solvable by agreement or, if necessary, by order within a faculty. However, if more than one faculty is involved, things are more complex. The most promising way to overcome it is to start up a pilot project where committed colleagues cooperate. Thus, with a bit of good will, that problem can be solved as well.

There remains the problem of financial and human resources. This is, indeed, not solvable using conventional means.

Nonetheless, with modern means, there is a good chance to save the approach of micro-modularized curricula. If many working groups are developing in parallel different modules for computer-supported teaching, and provided they share their efforts, then it will be possible to find a novel combination of presence learning and distance learning. There, those modules could be used to realize a condensed curriculum with a sensible amount of effort and of resources. Comprehension of the material is then improved instead of worsened.

While the duration of time for studying a subject will thus be shortened without worsening the level of quality, it must be clear that the compression of the course material will require its price: it will be even harder to study a demanding discipline.

## 7. Conclusion

A proposal was sketched that has the potential of shortening the average time of study courses while preserving or even improving comprehension of the taught material. The proposed method is the technique of micro-modularization of lecture-content and of cooperative teaching.

A prerequisite for a successful realization of these ideas is the cooperation of many parties. Effective working groups must be formed. They have to completely revise curricula. These must be reformulated on a basis of learning-modules. The latter do not necessarily belong to one single scientific department or faculty or even

university. Learning-modules must be implemented, be it as concepts for presence learning, or be it as implementations for computer-based or distance learning.

This author is a strong believer not only in the feasibility but also in the necessity of such a project. Networks of cooperation such as the THEIERE project of the European community [5] could be a basin for attracting open-minded professional lecturers, students and, hopefully, politicians and industrial partners to form a pilot project.

## 8. References

- [1] The European Space for Higher Education, *Joint Declaration of the European Ministers of Education Convened in Bologna on the 19th of June 1999* [online]: <http://www.murst.it/convegna/bologna99/dichiarazione/english.htm>
- [2] The Association of Universities and other Higher Education Institutions in Germany - Hochschulrektorenkonferenz (HRK), *Positionen der HRK zur künftigen Entwicklung des Wissenschaftssystems in Deutschland*, (in German), Bonn, Feb. 2001 [online]: [http://www.hrk.de/vbsmodule/texte/std\\_text.asp?str\\_CallFile=texte/archiv/Entschliessungen/Plen193\\_3.htm#1](http://www.hrk.de/vbsmodule/texte/std_text.asp?str_CallFile=texte/archiv/Entschliessungen/Plen193_3.htm#1)
- [3] K.C. Gupta, "Concept Maps and Modules for Microwave Education", *IEEE Microwave Magazine*, vol.1, no.3, September 2000, pp. 56-63.
- [4] T. Buzan and B. Buzan, *The Mind Mapping Book*, Penguin, Baltimore, 1996.
- [5] European Association for Education in Electrical and Information Engineering (EAEEIE), *THEIERE thematic network*, 2000 [online]: <http://www.eaeie.org/theiere/>