

Distance Seminar Environment Using Gigabit Network

Toshihiro Hayashi and Yukuo Hayashida

Department of Information Science, Saga University

{hayashi, hayasida}@is.saga-u.ac.jp

Abstract

We report design and implementation method of Distance Seminar System. If a professor can use network-reachable device at the destination of official trip, s/he can realize quasi-seminar by time arrangement with her/his students and utilization of network applications. We call this type of seminar "distance seminar". Our distance seminar system connects with two points: instructor side and student side. We adopt gigabit network as high-speed network in order to realize transmission of high-quality audio/video stream for educational contents.

1. Introduction

Recently, distance education is getting popular in utilization of information network and there are a lot of studies about the educational method and computer support system[1,2]. In addition, we will be able to use high-speed network such as gigabit network in near future and many research activities have been started.

Considering this situation of information network and distance education, we believe that it is necessary to develop applications based on utilization of high-speed network including gigabit network. On the other hand, there are many applications for low-speed network and we can use some of them for high-speed network[3]. For this reason, we combine both applications for high-speed and low-speed in order to construct distance education system. As for new applications for this idea, we are going to develop several applications which can treat with points that our idea based system cannot support. By combination of various kind of network application, we can realize flexible system for distance education. This paper especially discusses about construction method of distance seminar system.

2. What is Distance Seminar ?

Information network such as Internet has been rapidly developed so that distance education is getting more popular in higher education. As for the curriculum of university (especially, science and engineering course), it is

standard that students attend lectures from the freshman year to the junior year and then they are assigned to laboratories for writing graduation thesis in the senior year. In the viewpoint of utilization of distance education, normal lectures which many students attend are often given as distance lecture. On the other hand, seminar in laboratory has small number of the students so that utilization of distance education is not so popular.

Generally, lectures and official meetings have high priority so that professors must plan laboratory seminars and official trips within the remaining time. If a professor goes on a official trip, the seminar is not given until s/he returns. However, the professor is not always restricted by her/his business at the destination and s/he can get free time. If the professor can use network-reachable device at the destination, s/he can realize quasi-seminar by time arrangement with her/his students and utilization of network applications. We call this type of seminar "distance seminar".

3. Distance seminar model

In this section, we first explain a model of general seminar and then we propose models of distance seminar in order to articulate the structure of distance seminar.

3.1 Model of general seminar

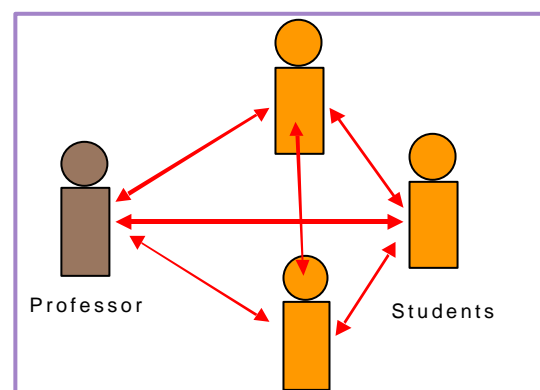

Figure 1 General seminar model

We propose a model of general seminar. **Fig. 1** shows the general seminar model. This model consists of a professor and several students. In this model, the professor and students are in same room at same time. Especially, we put focus on the feature of "same time and same location" in general seminar.

3.2 Model of distance seminar

Generally, the feature of "same time and same location" is broken in distance seminar. **Fig. 2** shows a typical model of distance seminar. In this model, the professor is not in students' place. We think distance seminar has a feature of "same time but different locations".

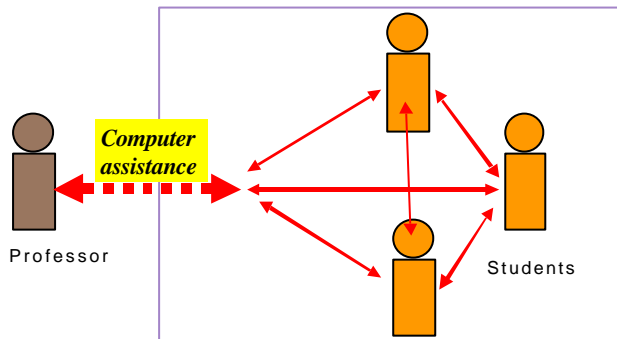

Figure 2 Typical model of distance seminar

In the typical model of distance seminar, the professor cannot communicate with her/his students but students can interact with other students. This means computer assistance should be basically adopted to the communication between the professor and students. The assistance clears the problem of different locations.

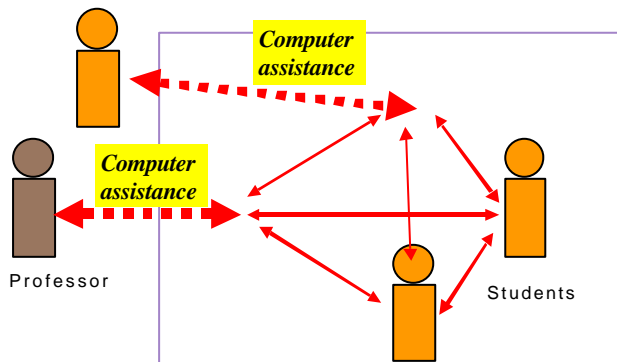

Figure 3 Another distance seminar model

3.3 Perturbation of distance seminar model

In some cases, some students might be in different places. **Fig. 3** shows such a situation. This case is also categorized in distance seminar. This suggests that distance seminar model has perturbation in its structure.

In this way, we must take care of this feature of distance seminar. In order to construct distance seminar system, flexible configuration is required by:

- (1) various kinds of situations of "Same time but different locations",
- (2) restriction of available PC equipment and
- (3) some other conditions.

We propose two ideas to construct computer assisted distance seminar system. One is "Multi-Applications with Single Function model" and the other is "MHB(Media Handling Block)". The former is described in section 4 and the later is described in section 5.

4. Basic construction model for distance seminar

Our research aim is to construct a computer system for distance seminar by using gigabit network. As for the first step of the construction, we propose a construction model for distance educational system using high-speed network such as gigabit network[3]. In this paper, distance seminar system belongs to distance educational system.

4.1 Applications for distance education

The development of research works about distance education, a lot of models and methods for constructing distance education environment and the support systems in the environment have been proposed. In addition, various kinds of (network) applications have been developed based on the models and methods. As for the other typical construction style, many applications not for distance education but for general use of information network are often used in computer support system for distance education.

When the utilization of gigabit network is getting general in near future, we think many new and various kinds of applications will be developed and used for distance education. In this case, we think that distance education system consists of existing applications for current network (low-speed network) and new application for high-speed network.

4.2 Classification of application for distance education

We classify applications for distance education into "single-Function Application" and "Multi-Function Application" focusing on "the number of functions". Single-

Function Application provides single (or a few) operation(s) for single media. The one of examples is an accessory program for playing CD on PC. On the other hand, Multi-Function Application integrates various kinds of media and provides multi-functions for the multimedia. The typical example is Microsoft NetMeeting.

Based on the classification of applications described in this section, we propose two types of models of computer system for constructing and supporting distance education in the following:

- (1) Distance education system integrating complement plural Single-Function Applications, and
- (2) Distance education system based on single Multi-Function Application.

In this paper, the former is called MASF model(Multi-Applications with Single Function model) and the latter is called MFSA model(Multi-Functions on Single Application model). Fig. 4 and 5 shows conceptual configuration of two models for distance education system.

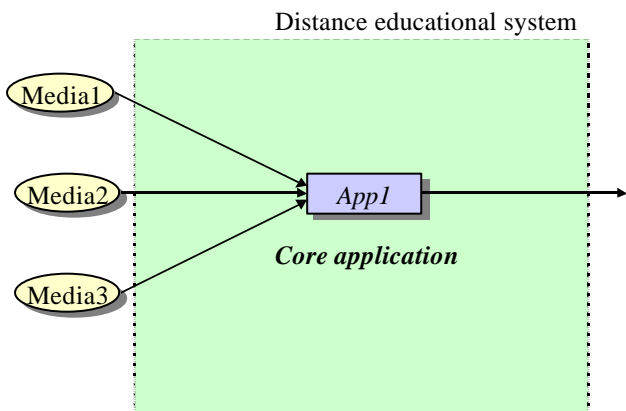

Figure 4 Multi-Functions on Single Application model

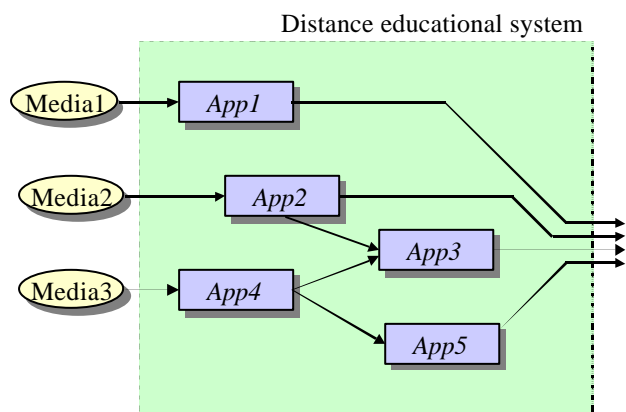

Figure 5 Multi-Applications with Single Function model

These models are both realistic to construct distance education. However, we adopt MASF model because of the following reasons:

- (1) There is high possibility that applications for high-speed and low-speed are mixed in distance education system, and
- (2) Some of applications for low-speed network can be used in high-speed network oriented application.

This means MASF model is more flexible than MFSA model because the former allows various kinds of combination of applications.

4.3. Example of MASF model based system

We are currently developing several application for distance seminar based on MASF model. In this subsection, we introduce two applications for transmitting high-quality video stream as the example.

4.3.1 System environment

Fig.6 shows the computer environment for the system. There are two PCs in this environment. One PC is connected with a video camera and it is used as sender host. On the other hand, the other PC is used as receiver host. The two PCs are connected by high-speed network. Our applications run on the hosts.

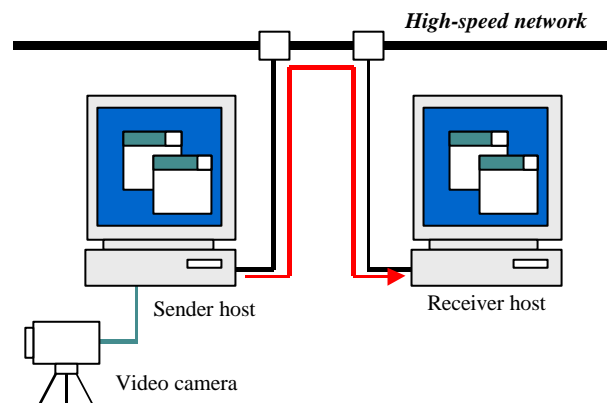

Figure 6 System environment using high-speed network

4.3.2 Video stream sender

Video stream sender is executed on the sender host. This application has following features:

- (1) capturing snapshots using connected video camera,
 - (2) adaptive compression of the snapshot data by monitoring network status, and
 - (3) sending snapshots as motion-JPEG to receiver host.
- Especially, this application monitors RTD (Round Trip Delay) of the network and computes appropriate compress-

sion ratio to send data smoothly. **Fig. 7** shows the snapshot of video stream sender. The compression ratio can be changed manually and automatically.

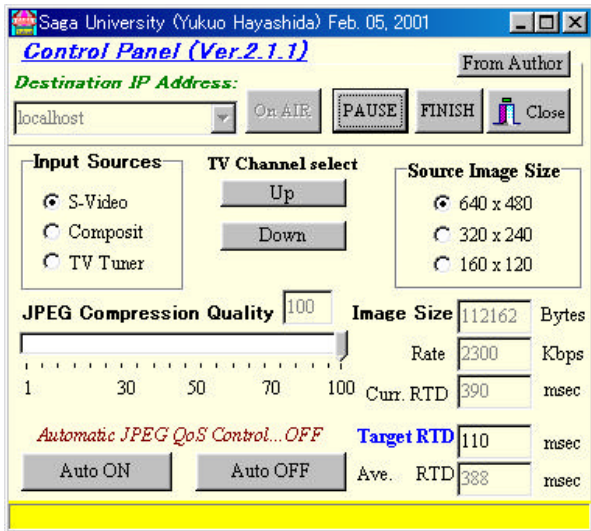

Figure 7 Video stream sender

4.3.3 Video stream receiver

Video stream receiver is executed on the receiver host. This application has following features:

- (1) receiving motion-JPEG data from receiver host.,
- (2) decompression of the JPEG data, and
- (3) playing them continuously.

Especially, this application can store the JPEG data with sequential number into local second memory device (mainly into hard disk). The stored data can be played whenever continuously based on the sequential number. **Fig. 8** shows the snapshot of video stream receiver.

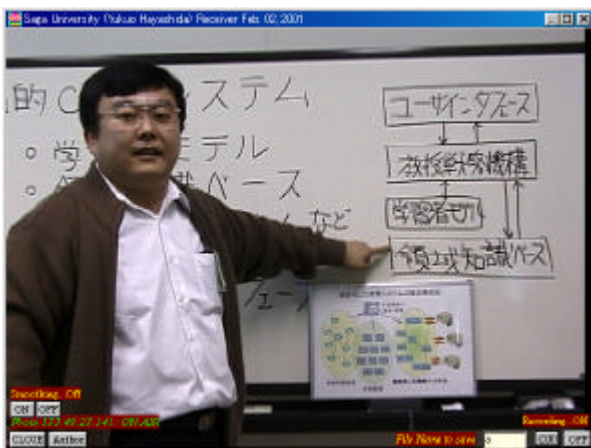

Figure 8 Video stream receiver

4.3.4 How to use them with other applications

MASF model requires utilization of plural applications. We explain a simple example of how to use video stream sender and receiver.

Generally, video stream is input from peripheral device interface. There are various kinds of interface such as traditional video board (card), USB, IEEE1394 and even parallel port. The current version of our applications can capture video data via IEEE1394 and a vendor-dependent video board. If someone wants to use plural video streams at same time, our system can provide the following solution.

For higher-quality video data transmission, our application can be used via video board. For the other video data transmission, the other application could be used via USB and so on. As for a concrete example, we have already confirmed we can use our applications and Microsoft NetMeeting at same time

5. MHB: Media Handling Block

MASF model provides a guidelines how to construct distance seminar system by integration of plural media applications. However, this model does not provide the features of integrated application (what kind of functions are in the application?). Media Handling Block (called MHB hereafter) is general style of integrated application and provides general functions of the integrated application.

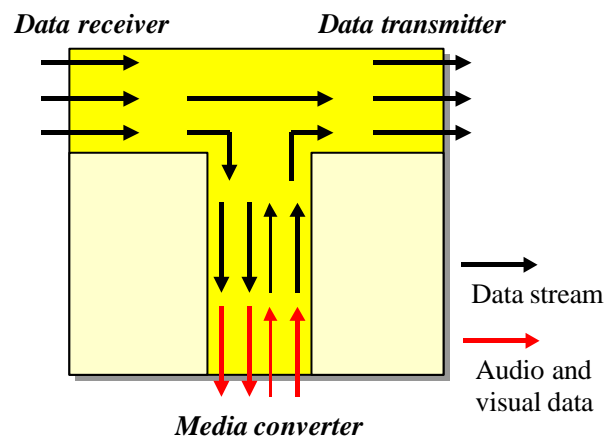

Figure 9 MHB: Media Handling Block

5.1 Functions of MHB

We propose three functions of MHB in the following:

- (1) *Data transmitter*: transmits data stream to other systems,

- (2) *Data receiver*: receives data stream from other systems, and
- (3) *Media converter*: converts data stream to audio and visual data and converts audio and visual data to data stream.

Fig. 9 shows an illustrated model of MHB. In this model, data stream is input from other application and is output to other application. In other words, data stream passes through MHB. Audio and visual data can be exchanged to data stream by media converter function.

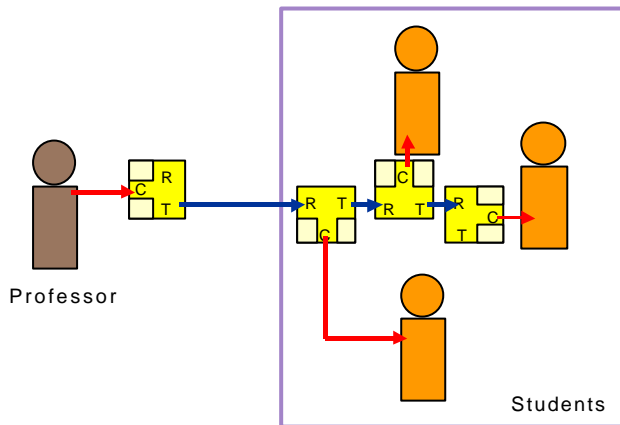

Figure 10 system configuration (1)

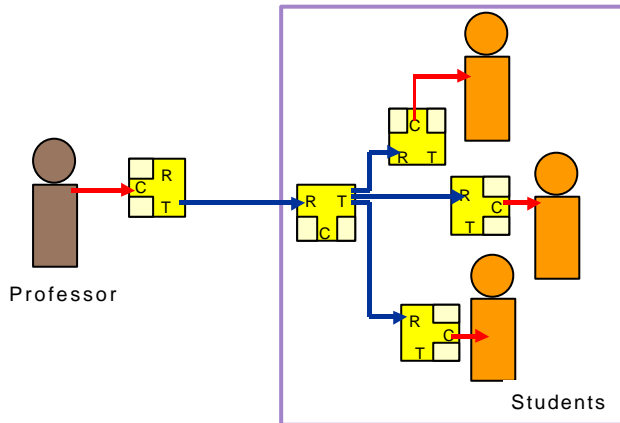

Figure 11 system configuration (2)

5.2 System configuration based on MHB

Fig. 10 shows a typical configuration of distance seminar based on MHB. In **Fig. 10**, MHB functions are represented as T(Data transmitter), R(Data Receiver) and C(Media converter). In this configuration, the professor and all students have own PC (desktop PC or note PC). In each PC, distance seminar system is installed. In this situation, we can replace each PC to MHB. **Fig. 10** shows the

concept configuration. Data from the professor can be transmitted to all students by bucket-relay among MHBs.

Fig. 11 shows another configuration of distance seminar system. In this situation, there is one excessive computer. This computer is used such as reflector so that students' computers do not have to pass stream data to other PCs. If students have low spec PCs, this configuration becomes better solution to construct distance seminar.

In this way, MHB requires unicast data transmission. **Fig.10** and **11** do not suggest data transmission from students to the professor. Generally, this type of data transmission requires wide-bandwidth so that we can say this construction model is based on high-speed network such as gigabit network.

6. Summary

This report described the construction model for distance seminar based on the utilization of gigabit network. Especially, the style of distance seminar is educationally effective as the education style that realizes pseudo-seminar when the instructor cannot participate in a seminar. This report especially explained a system construction model as the general method to construct distance seminar focusing on MASF model and MHB.

As for our future work, we are going to construct Single-Function applications for distance seminar and integrate them and existing network applications. We also plan to experiment about distance seminar using JGN(Japan Gigabit Network).

References

- [1] Sugai, K.: "Review of Research on Educational Systems", *Japan Journal of Educational Technology*, Vol.21, No.4, pp. 203-208(1998) in Japanese.
- [2] Watanabe, K.: "Activities of the Internet Use in Classroom", *Transaction of Japanese Society for Information and System in Education*, Vol.16, No.2, pp.111-118(1999) in Japanese.
- [3] Hayashi, T. and Hayashida, Y.: "Educational Systems Using Gigabit Network", *Technical Report of IEICE*, ET99-102, pp.53-58(2000) in Japanese.
- [4] Hayashi, T., Sagata, K. and Hayashida, Y.: "Development of Video Data Transmission System Focusing on Round Trip Delay for Distance Education", *Technical Report of IEICE*, ET2000-141, pp.211-218(2001) in Japanese.
- [5] Hayashi, T. and Hayashida, Y.: "Remote Seminar System Using Gigabit Network", *Proceedings of 2001 Annual Conference of Japanese Society for Information and System in Education*, to be published(2001).